



**LEO, the smart
drive system,
which moves a lot with ease**



touch²move



Small Goods Handling Specialists

The smart drive system which moves a lot with ease!

The single-handed tug "LEO" combines the patented touch2move drive concept with the principles of motorized ground transport equipment with pole-shaft control. The compact combination of sensor handle & high-torque drive motor ensures optimum manoeuvrability plus effortless towing and parking of one or more trolleys/carts.



The sensor handle of
the patented concept...

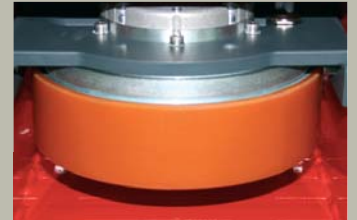

...controls the
smart drive!



LEO750

LEO750, stainless steel version with
electromechanical universal coupling mechanism



LEO750

LEO750 for effortless, precise parking



LEO750

LEO750 with customized electromechanical
coupling mechanism



LEO750

LEO750 with electromechanical adapter made of stainless steel.
Individual adapters are made to customer specifications.

Ergonomic goods movement leads to reduced absenteeism and increased productivity.

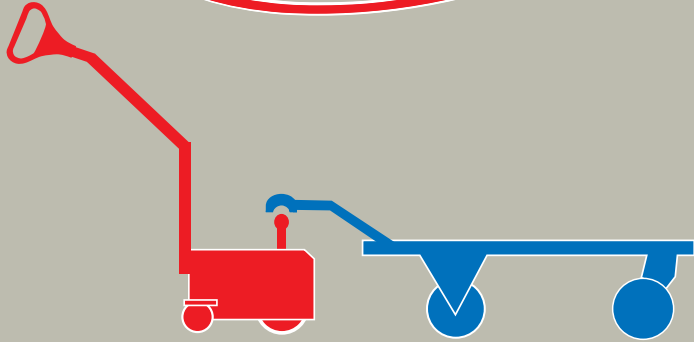

LEO2500

LEO2500 with universal, electrohydraulic coupling mechanism



LEO2500

LEO2500 with customized adapter for mesh pallets on load carriers



LEO2500

LEO2500 for safe handling, acceleration, and braking of payloads up to 2500 kg

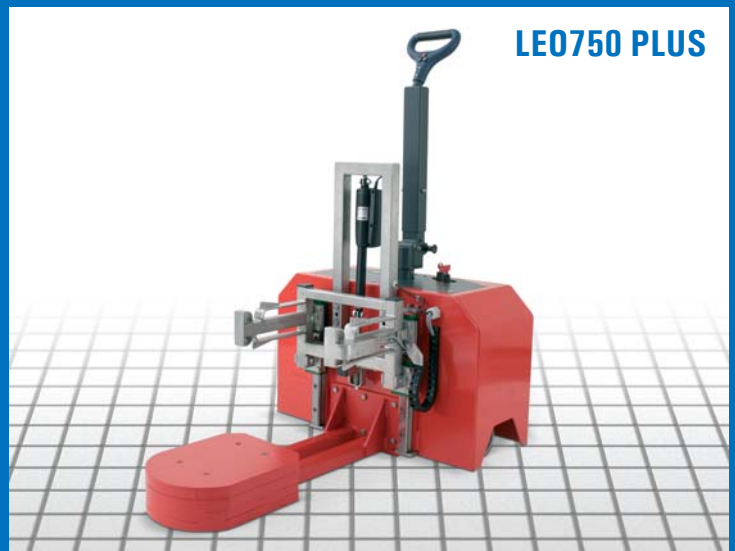

LEO750 PLUS

LEO750 PLUS with electromechanical coupling mechanism for use on load carriers with four swivel castors

Unique advantages:

- ✓ The LEO drive concept is based on the established touch2move sensor technology
- ✓ Sensor handle with capacitive hand detection, integrated button for On/Off, and multi-colour LED indicators for battery status and error messages
- ✓ Simply by touching the ergonomic sensor handle, the LEO "obeys" the operator's natural movements, enabling loads up to 2,5 tons to be moved effortlessly.
- ✓ Intuitive operation – without special training or a driving license
- ✓ Outstanding manoeuvrability – turning point is located centrally, so that the load carrier can be turned on the spot
- ✓ Two independent braking systems provide high safety – dynamic braking via the drive motor plus electromechanical parking brake (automatic brake application when sensor handle is released).
- ✓ Efficient and ergonomic goods movement with the LEO leads to reduced absenteeism and increased productivity
- ✓ Flexible multi-shift operation, thanks to optional battery exchange system
- ✓ Extremely space-saving when compared to forklifts or other bulky transport vehicles
- ✓ Subsidies from Inclusion Offices are possible
- ✓ CE conformity in accordance with Machine Directive 98/37/EEC



Height-adjustable sensor handle with capacitive hand detection, integrated Emergency Off button, and keyswitch



Simply by touching the ergonomic sensor handle, the LEO "obeys" the operator's natural movements

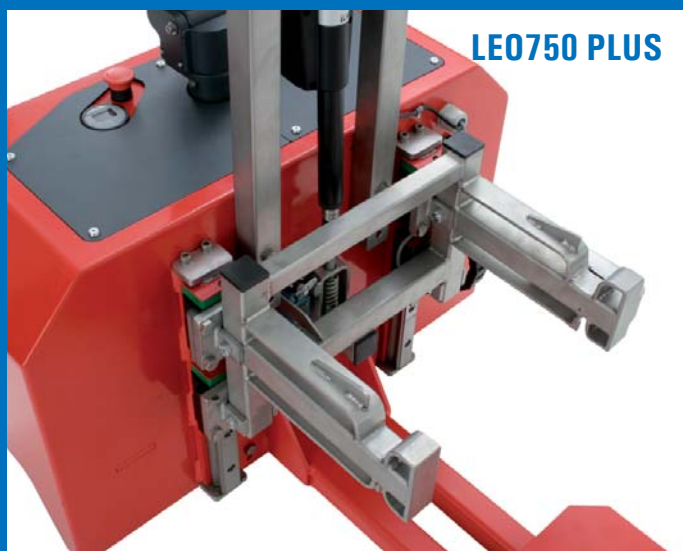

LEO750 PLUS: Special coupling adapter for load carriers with four castors



LEO2500 PLUS with keyswitch, Emergency Off button, additional battery cut-off switch, and LED indicators for battery status



**Simply take hold
and off you go!**



EXPRESSO Deutschland GmbH
Antonius-Raab-Str. 19 • 34123 Kassel/Germany
Tel.: +49 5 61 - 95 91-0 • Fax: -138
expressoinfo@JLU.de • www.expresso.de

EXPRESSO Transportgeräte GmbH
Perfektastr. 61/3 • 1230 Wien/Austria
Tel.: +43 1/332 41 41-0 • Fax: -71
office@expresso.at



LE0750

Stainless steel version of LE0750: Detail of electrohydraulic adapter for use in a medical application



LE02500

Special version of LEO tug in an assembly line for buses & commercial vehicles



LE02500

Outstanding manoeuvrability:
Load carriers can be turned on the spot



LE0750

LE0750 being docked to a four-wheel cart



Technical Information

	LE0750	LE02500	LE0750 PLUS	LE02500 PLUS
Max. payload in kg	750	2,500	1,000	2,500
Own weight in kg	200	600	270	300
Length of drive module in mm	980	680	320	430
Length with coupling mechanism in mm	1,220	1,200	780	780
Width in mm	620	610	620	620
Height of drive module in mm	260	530	530	530
Height including pole-shaft in mm	1,030 (950-1150)	1,010	1,070	1,070
Motor and Drive unit	Electronically communicating hub drive motor (gearless)	Three-phase hub motor with planetary gear	Electronically communicating hub drive motor (gearless)	Three-phase hub motor with planetary gear
Power in W	200	600	200	600
Max. Torque in Nm	72	170	72	170
Protection class	IP54	IP43	IP54	IP43
Battery exchange system	optional	optional	-	-
Maintenance-free lead gel-cell batteries	2 x 12 V / 50 Ah	2 x 12 V / 100 Ah	2 x 12 V / 50 Ah (optional: 2 x 12 V / 100 Ah)	2 x 12 V / 100 Ah
Operating voltage in V	24	24	24	24
Battery charger in A	8	8	8	8
Coupling mechanism	Ball-head or hook for drawbar	Ball-head or coupling for drawbar	-	-
Options	universal, electromechanical docking mechanism, adjustable height	universal, hydraulic docking mechanism with adaptable coupling hook	individual design to customer specifications	individual design to customer specifications
Operating controls and display elements	Controller with display of battery capacity and operating hours			
	Emergency stop-button with integrated keyswitch	Emergency Stop button + Seperate keyswitch		
	Battery master switch			
Braking system	1) Regenerative brake (braking torque of motor)			
	2) Spring-operated, multi-plate brake (electrically released when sensor handle is grasped)			
Sensor handle	capacitive hand detection			
	Driving direction and speed controlled via built-in pressure sensors			
	Battery and status indication (LED green / yellow / red)			
	Horn button			
	Up/Down buttons (for coupling mechanism or additional functions, e.g. lifting/lowering)			
Speed in km/h	0-6	0-5	0-6	0-5
Driving requirements	only familiarization, no driving license required			

All text and photo rights reserved exclusively for EXPRESSO Deutschland GmbH. Technical details are subject to change in the interest of constant product improvement. LE0le0809

Small Goods Handling Specialists – Worldwide